

# LT5.0 Mini Crawler Crane spider crane

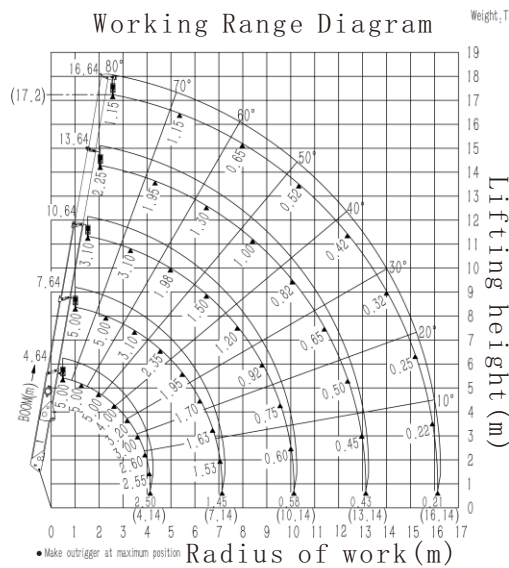

4 Fall—17.5m  
 2 Fall—35.0m  
 1 Fall—70.0m

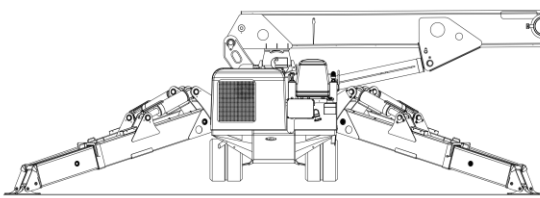
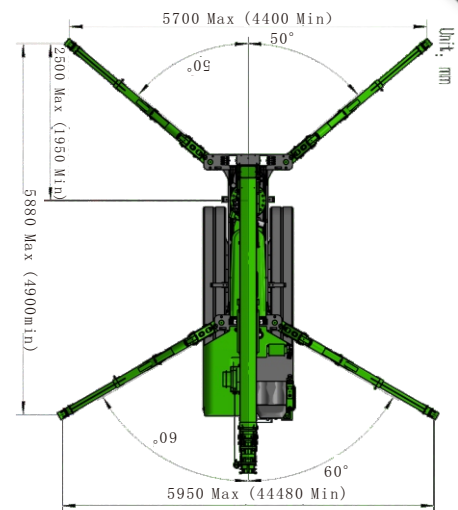

Outrigger Footprints

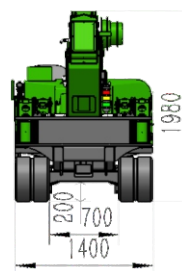
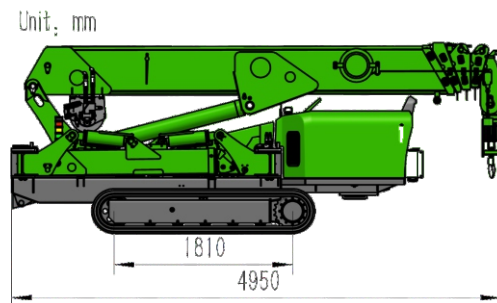

Dimensions

Website: [www.levoltspidercrane.com](http://www.levoltspidercrane.com)

Tel: 0086 (371) 57157086

Email: [info@levoltcrane.com](mailto:info@levoltcrane.com)

Model		LT5.0
Capacity		5.0t×2.2m
Working radius		16.14m×0.21t
Ground lifting height		17.2m×1.15t
Underground lifting height		17.5mX2.5t(4 fall) 35mX2t(2 fall) 70mX1t(1 fall)
Winch device	Hook speed	0-14m/min (4 fall )
	Rope type	Φ10mm×80m ( Minimum breaking force 90.1KN 1960N/mm <sup>2</sup> )
Telescopic system	Boom form	5 section boom, hexagonal box construction
	Boom length/Time	4.64m-16.64m/45sec
Up and downs	Boom angle/Time	0-80°/18sec
Slew system	Slew angle/Speed	0-360° ( continuous ) /30sec
Outrigger	Outrigger active form	Manual+Hydraulic
	Maximum extended dimensions (mm)	5880 ( Length ) X5700 ( Front ) X5950 ( Back )
Traction system	Walking way	Hydraulic motor drive、 2 speed
	Walking speed	0-3km/ h
	Grade ability	20°(36%)
	Ground length×width	1810mm×350 mm
	Ground pressure	44kpa ( 0.45 kgf / cm <sup>2</sup> )
Electric motor	Voltage	AC380V ( Optional )
	Power/Speed	7.5kw/1440 min-1
	Sound level	Rated speed ≤60dB(A) ( 1m )
Diesel engine	Model	3TNV80F (YANMAR)
	Type/Displacement	3 cylinder water cooled/1.266L
	Rated output	14.6kw/2400 min-1
	Starting method	Electric
	Operating temperature	-5°C~40°C
	Fuel/Volume	Diesel/40L
	Battery capacity	12v 45AH
	Specific fuel consumption	272g/kW-h
	Sound Level	Rated speed ≤83.5dB(A) (1m)
	Applied regulation	EPA-Tier4 , China phase 4
Operate system	Type of operation (crane, walk, leg, accelerator )	Wireless remote control and Dual axis joystick controller
	Operating characteristic	Full proportional control and Proportional joystick control
Dimension	Length×Width×Height	4950mm×1400mm×1980mm
Weight	(Without optional equipment )	5750kg
Standard equipment	Diesel engine and motor (Dual power)、 Proportional joystick control and wireless proportional remote (Dual operation mode) 、 Intelligent display screen、 Moment limiter、 Over hoist alarm and automatic stop device、 Three-winding alarm and automatic stop device、 Automatic hook stop、 Outrigger position detector device、 Outrigger off ground (or crane body 3-degree inclination)alarm and automatic stop device、 Slings rope detachment protector、 EMO switch、 Three color lamp、 Remote control lamp、 Voice prompt、 Walking/Outrigger/Boom three-mode interlock system、 Data records	
Optional equipment	Searcher hook (0.7t) 、 Fly jib(0.8t)、 Single fall hook、 Outrigger Pads、 Man basket	