

# LT4.0 Mini Crawler Crane spider crane

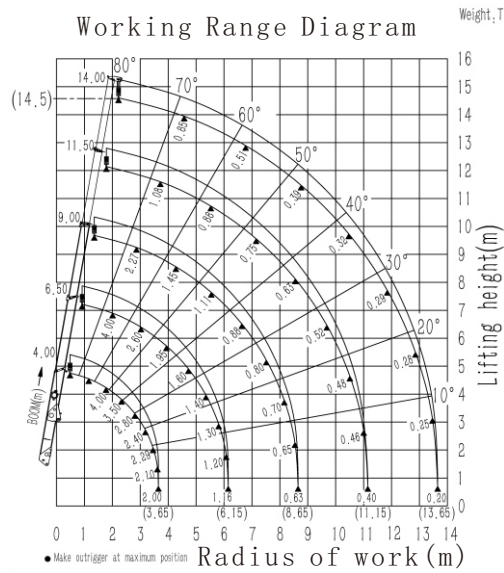
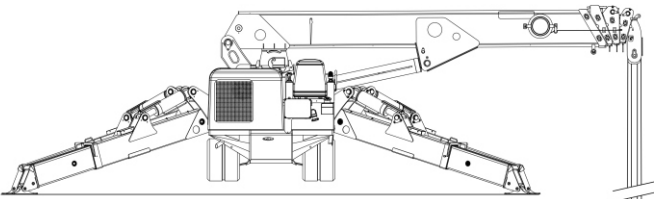

4 Fall—16.0m

2 Fall—32.0m

1 Fall—64.0m

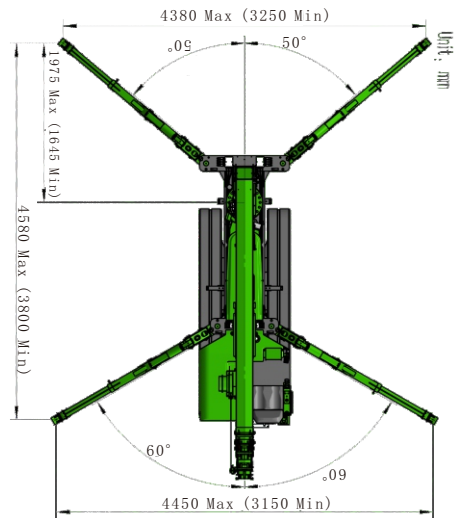

Outrigger Footprints

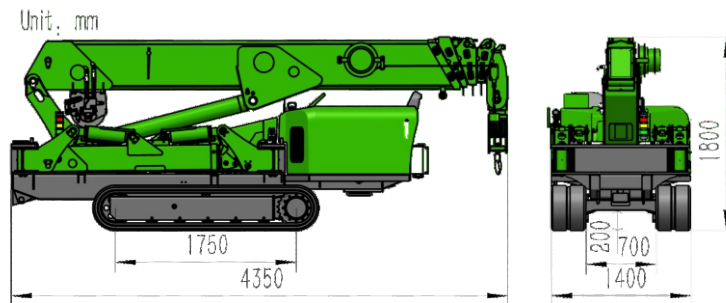

Dimensions

Website: [www.levoltspidercrane.com](http://www.levoltspidercrane.com)

Tel: 0086 (371) 57157086

Email: [info@levoltcrane.com](mailto:info@levoltcrane.com)

Model		LT4.0
Capacity		4t×2m
Working radius		13.65m×0.20t
Ground lifting height		14.5mX0.85t
Underground lifting height		16mX2t(4 fall) 32mX1t(2 fall) 64mX1t(1 fall)
Winch device	Hook speed	0-12m/min (4 fall )
	Rope type	Φ8mm×73m ( Minimum breaking force 60.6KN 2160N/mm <sup>2</sup> )
Telescopic system	Boom form	5 section boom, hexagonal box construction
	Boom length/Time	3.54m-12.3m/25sec
Up and downs	Boom angle/Time	0-80°/14.5sec
Slew system	Slew angle/Speed	0-360° ( continuous ) /30sec
Outrigger	Outrigger active form	Manual+Hydraulic
	Maximum extended dimensions (mm)	4580 ( Length ) X4380 ( Front ) X 4450 ( Back )
Traction system	Walking way	Hydraulic motor drive、 2 speed
	Walking speed	0-3km/ h
	Grade ability	20°(36%)
	Ground length×width	1750mm×300 mm
	Ground pressure	42.8kpa ( 0.437 kgf/cm <sup>2</sup> )
Electric motor	Voltage	AC380V ( Optional )
	Power/Speed	5.5kw/1440 min-1
	Sound level	Rated speed ≤60dB(A) ( 1m )
Diesel engine	Model	3TNV80(YANMAR)
	Type/Displacement	3 cylinder water cooled/1.266L
	Rated output	14.6kw/2400 min-1
	Starting method	Electric
	Operating temperature	-5°C~40°C
	Fuel/Volume	Diesel/40L
	Battery capacity	12v 45AH
	Specific fuel consumption	272g/kW-h
	Sound Level	Rated speed ≤83.5dB(A) (1m)
	Applied regulation	EPA-Tier4 , China phase 4
Operate system	Type of operation (crane, walk, leg, accelerator )	Wireless remote control and Dual axis joystick controller
	Operating characteristic	Full proportional control and Proportional joystick control
Dimension	Length×Width×Height	4350mm×1400mm×1800mm
Weight	(Without optional equipment )	4700kg
Standard equipment	Diesel engine and motor (Dual power)、 Proportional joystick control and wireless proportional remote (Dual operation mode) 、 Intelligent display screen、 Moment limiter、 Over hoist alarm and automatic stop device、 Three-winding alarm and automatic stop device、 Automatic hook stop、 Outrigger position detector device、 Outrigger off ground (or crane body 3-degree inclination)alarm and automatic stop device、 Slings rope detachment protector、 EMO switch、 Three color lamp、 Remote control lamp、 Voice prompt、 Walking/Outrigger/Boom three-mode interlock system、 Data records	
Optional equipment	Searcher hook ( 0.7t ) 、 Fly jib(0.8t)、 Single fall hook、 Outrigger Pads、 Man basket	