

LT2.0 Mini Crawler Crane spider crane

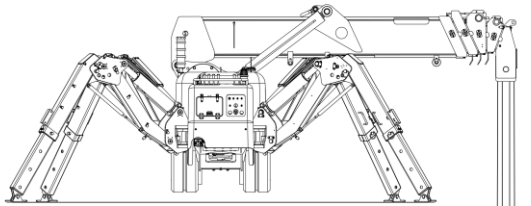

Working Range Diagram

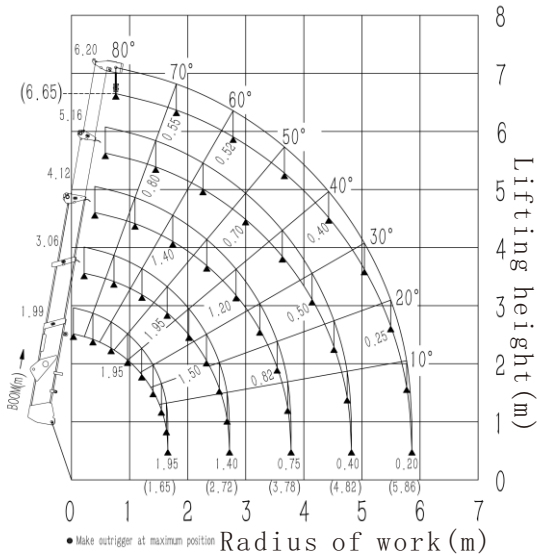

Weight, T

Lifting height (m)

4 Fall-10.0m

2 Fall-20.0m

1 Fall-40.0m

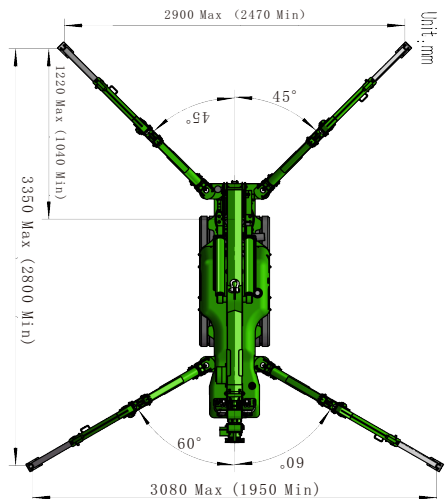

Outrigger Footprints

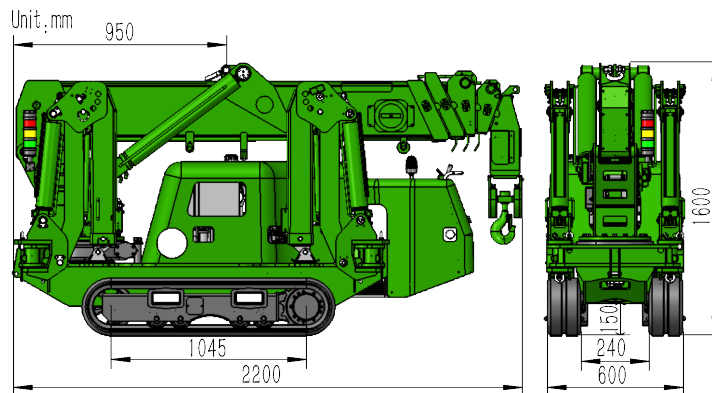

Dimensions

Website: www.levoltspidercrane.com

Tel: 0086 (371) 57157086

Email: info@levoltcrane.com

Model		LT2.0
Capacity		1.95t×1.75m
Working radius		5.86m×0.20t
Ground lifting height		6.65mX0.55t
Underground lifting height		10mX1t(4 fall) 20mX1t(2 fall) 40mX0.74t(1 fall)
Winch device	Hook speed	0-8m/min (4 fall)
	Rope type	Φ8mm×50m (Minimum breaking force 60.6KN 2160N/mm ²)
Telescopic system	Boom form	5 section boom, hexagonal box construction
	Boom length/Time	1.99m-6.20m/30sec
Up and downs	Boom angle/Time	0-70°/20sec
Slew system	Slew angle/Speed	0-360° (continuous) /60sec
Outrigger	Outrigger active form	Manual+Hydraulic
	Maximum extended dimensions (mm)	3350 (Length) X2900 (Front) X3080 (Back)
Traction system	Walking way	Hydraulic motor drive
	Walking speed	0-3.0km/h
	Grade ability	20°(36%)
	Ground length×width	1045mm×180 mm
Electric motor	Ground pressure	44kpa (0.45 kgf/cm ²)
	Voltage	AC380V (Optional)
	Power/Speed	4kw
Battery	Sound level	Rated speed ≤60dB(A) (1m)
	Model	KD440 (KOHLER)
	Type/Displacement	Single cylinder air cooled/0.441L
	Rated output	8kw/3600 min-1
	Starting method	Electric
	Operating temperature	-5°C~40°C
	Fuel/Volume	Diesel/5L
	Battery capacity	12v 45AH
	Specific fuel consumption	240g/kW-h
	Sound Level	Rated speed ≤80dB(A) (7m)
Operate system	Applied regulation	EPA-Tier4
	Type of operation (crane, walk, leg, accelerator)	Wireless remote control and manual operation
Dimension	Operating characteristic	Full proportional control and linkage control
	Length×Width×Height	2200mm×600mm×1600mm
Weight	(Without optional equipment)	1700kg
Standard equipment	Manual and wireless proportional remote (Dual operation mode) 、 Display screen、 Moment limiter、 Over hoist alarm and automatic stop device、 Three-winding alarm and automatic stop device、 Automatic hook stow、 Outrigger working condition、 Outrigger off ground (or crane body 3-degree inclination)alarm and automatic stop device、 Slings rope detachment protector、 EMO switch、 Three color lamp、 Remote control lamp、 Walking/Outrigger/Boom three-mode interlock system、 Data records	
Optional equipment	Searcher hook (0.3t) 、 Fly jib(0.5t)、 Single fall hook、 Outrigger Pads、 Man basket	